



We are an ISO 9001:2015 Certified engineering firm,  
was established in 2010, to provide complete  
Fabrication solutions to the sheet metal industry for  
India and Globally.

A New Generation of Reliability

**KV  
KT LASER WORKS**

# FOUNDATION DETAILS:-

## ➔ Details of ownership of the company:

- Private Limited

## ➔ No. of years in existence:

- Established in 2010

## ➔ Address and Contact Number:

- **KY Laser Works Private Limited.,**  
Plot No 21, 3<sup>rd</sup> Phase,  
5<sup>th</sup> Main, Peenya Industrial Area  
Bangalore,  
Pin code - 560 058.  
Karnataka.  
INDIA.  
Mobile: +91 9741229983,9945722311,  
Landline : 080-41241458  
E-mail: [info@kylaserworks.com](mailto:info@kylaserworks.com)



**KY LASER WORKS PVT LTD**

# **OUR MISSION:-**

- **The ultimate goal of KY Laser Works is to have its own identity in the Sheet Metal industry as a most trusted Enterprise in all aspects and a one stop solution for high quality, time bound and cost effective products.**
- **KY Laser Works is committed to maintain 100% client's satisfaction by certain values.**
- **Deep Integrity & Ensuring Code of Conduct.**
- **Precious Timekeeping & Highest level of Accuracy .**
- **Potential Leadership with an Energetic Team.**
- **Sufficient Infrastructure for anytime Expansion.**
- **Continuous Growth and 100% Success.**
- **Take pride in our industry –leading custom metal services.**
- **Our methodology is focused on supporting each client with estimating, engineering, and project management**
- **Our mission is to work towards incessant pursuit for fulfilling customer requirements and we work together to strengthen our company's expansion.**

**KY LASER WORKS PVT LTD**

# **INTEGRITY & CODE OF CONDUCT:-**

- **Committed to deliver versatile metal components with full customer contentment, we give a true value to your project your investment with the execution of enterprise-class integration services. Our professional team is inspired globally to fulfill clients' complex needs thoroughly.**
- **Flexible Capacity to meet client's style and to build trust based relationship.**
- **It is our policy not to disclose any information about our clients to any other person or organizations. The information we received will be used only for which our client provided to us.**



**KY LASER WORKS PVT LTD**

# Organizational Chart

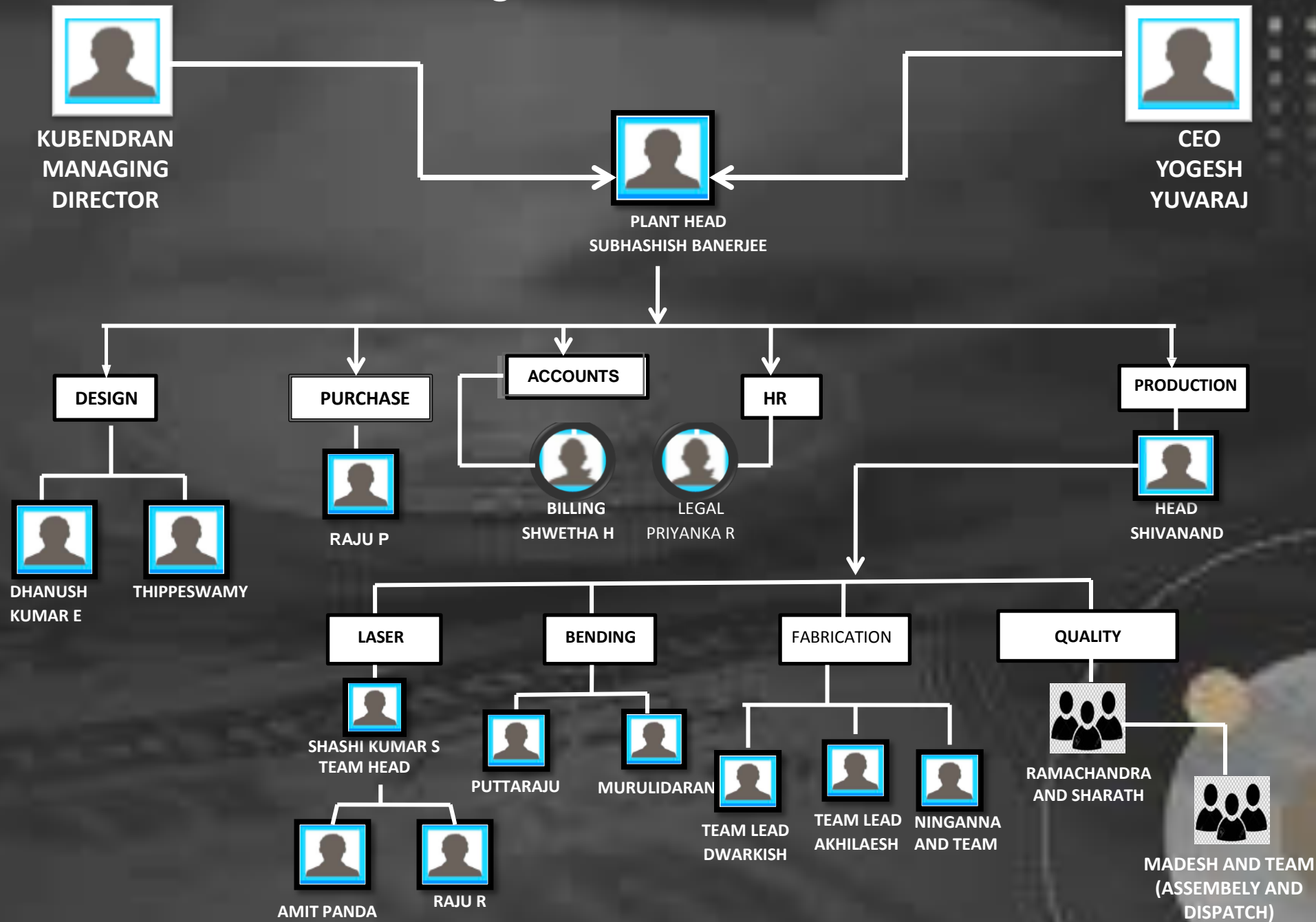

# Process Flow CHART

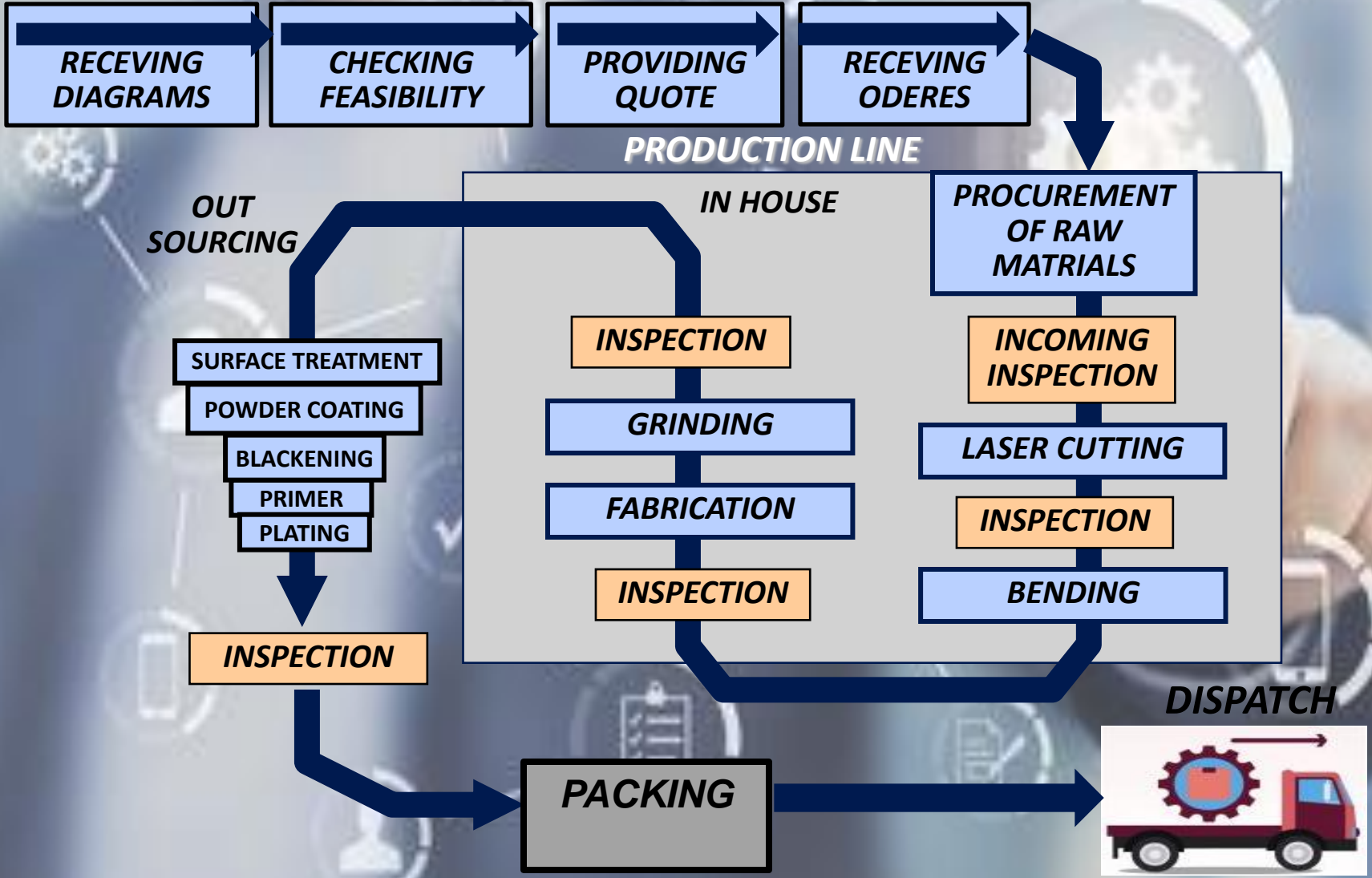

# ASSOCIATED WITH:-



**INNOVATION WITH PERFECTION**

# **TIME KEEPING AND ACCURACY:-**

- **We strongly believe that the speed & accuracy have to be balanced in track. Our young team is trained well to improve their speed day by day with 100% accuracy & flexible enough to work extra time even in non working days to complete the project in stipulated time.**



- **Setting benchmark continuously with integrated process & interaction between committed team members to ensure that quality levels are high from the initial stage of a project to its final outcome.**



# **LEADERSHIP AND TEAM:-**

- **We are a company with diverse talents & skills. Our leadership structure offers a dynamic atmosphere in which talented, creative & motivated people thrive. We don't just acknowledge hard work & achievements; we reward it & groom it.**
- **We have an experienced team of ambitious, vibrant, young professionals having ability to update with latest trends & requirements of our client.**
- **Our team's passion is to take challenges and to deliver to clients expectations.**



**KY LASER WORKS PVT LTD**

# QUALITY ISSUE:-

- **Ensure 99.95% accuracy**
- **A team of highly skilled and experienced versatile professionals is assigned as primary QCs and Final QCs to make sure that the output is 99.95% Quality assured and error free.**
- **We are ready to work for you exclusively.**



**KY LASER WORKS PVT LTD**

# INFRASTRUCTURE:-

- **Available Factory Space** : 10,000 sq feet (ground floor), 5000 sq feet(Spare Space)
- **Power Capacity** : 250 KVA
- **Material Handling** : Crane Capacity 5 Tons, Hydraulic trolley, Lift 3 ton capacity.
- **Power back up** : UPS
- **Transportation** : Own Transportation Vehicle
- **Monitoring** : Biometric scanner, CCTV cameras

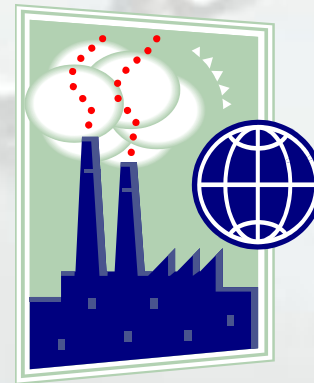

**KY LASER WORKS PVT LTD**

# AVAILABLE FACILITY | (LASER DIVISION) LASER CUTTING MACHINE:-



**Amada Laser Cutting Machine FOMII 3015NT 2.5 KWT**

**KY LASER WORKS PVT LTD**

# PRESS BREAK:-



**HACCO CNC Press Brake 6 axis machine  
(110 Ton capacity,3200mm Length)**

**KY LASER WORKS PVT LTD**

# PRESS BREAK:-

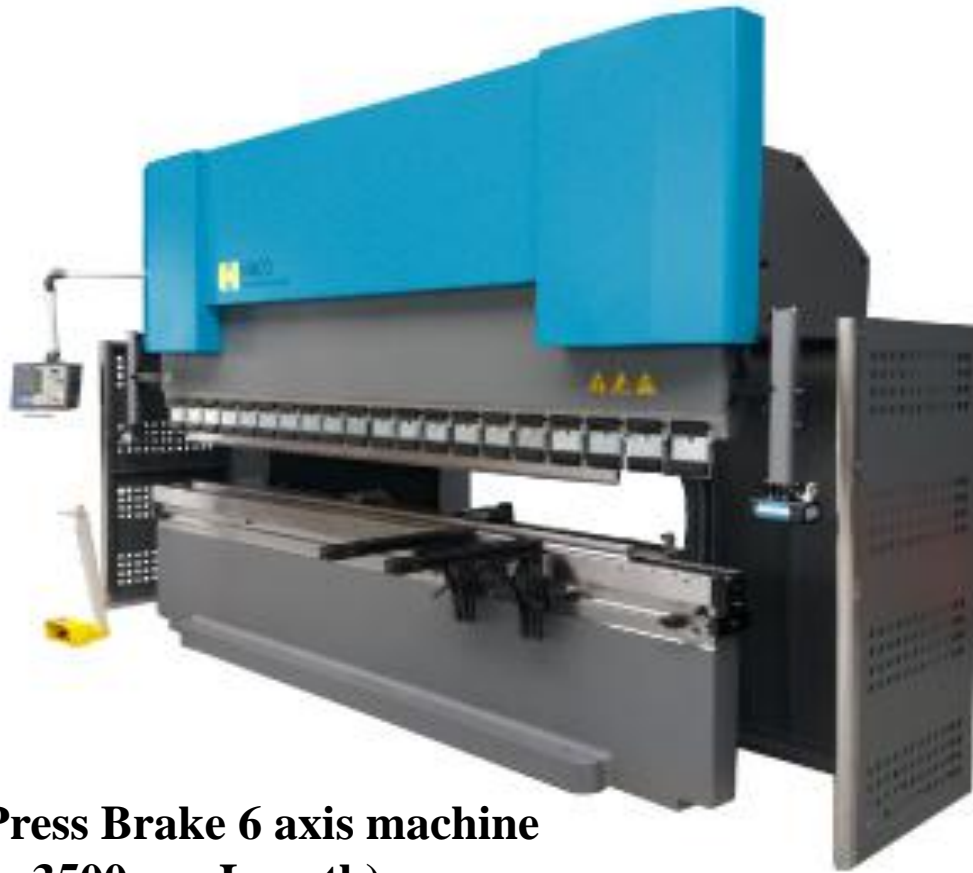

**HACCO CNC Press Brake 6 axis machine  
(150 Ton capacity,3500mm Length)**

**KY LASER WORKS PVT LTD**

# WELDING, DRILLING AND TAPPING MACHINES:-



**TIG Welding Machine**



**MIG Welding Machine**



**Drilling and Tapping  
Machines**

**KY LASER WORKS PVT LTD**

# TURRET PUNCH DIVISION:-



**Amada Turret Punching Ares 255**

**KY LASER WORKS PVT LTD**



# PRESS BREAKERS:-



**Accurpress Press Brake 110 Ton 3200  
Meters**



**Amada RG80 Press Brake**

**KY LASER WORKS PVT LTD**

# SHEARING MACHINE AND NUT INSERT MACHINE:-



**Heager Nut Insert Machine**



**Hindustan Hydraulics Shearing  
Machine**

**KY LASER WORKS PVT LTD**

# Tool Room Division:-



**DRO Milling Machine**



**Lathe Machine**



**Surface Grinding Machine**

**KY LASER WORKS PVT LTD**

# Welding and Riveting FACILITIES:-



FASTENER INSERTION MACHINE



CO2 MIG WELDING



CAPACITOR DISCHARGE

**KY LASER WORKS PVT LTD**

# Other Facilities:-



POP NUT INSERTS



PRESS TOOLS



PNEMATIC SANDERS

**KY LASER WORKS PVT LTD**

# Fitting and Fastening equipments:-



TUBE CUTTER



JIG SAW



AIR HYDRAULIC  
LOCK BOLT



LOBSTER REVERT GUN

**KY LASER WORKS PVT LTD**

# Punching machine:-



**KY LASER WORKS PVT LTD**

# Bending machine:-



**KY LASER WORKS PVT LTD**



# Our Products:-

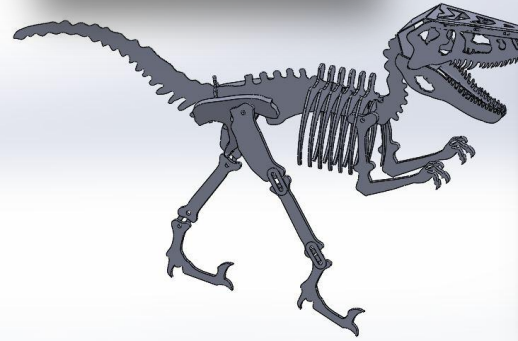
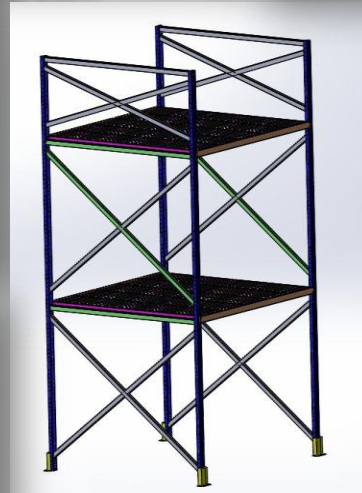
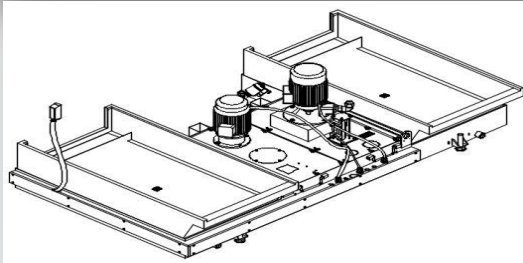
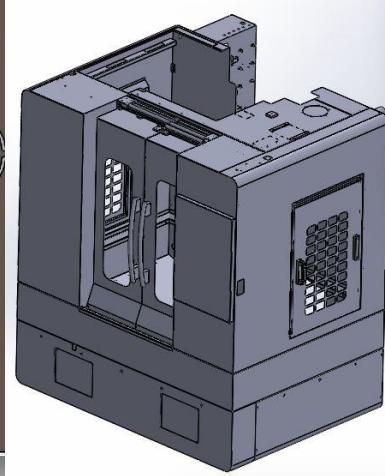
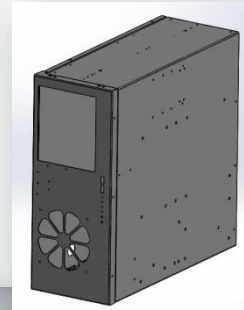
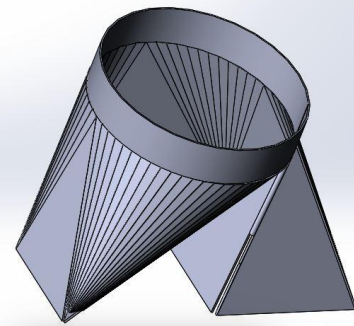
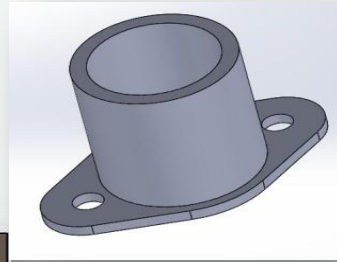



# Contact us:-

## KY Laser Works Private Limited.,

Plot No 21, 3<sup>rd</sup> Phase,  
5<sup>th</sup> Main, Peenya Industrial Area  
Bangalore,  
Pin code - 560058.  
Karnataka.

INDIA.

Mobile: +91 9741229983,9945722311

Landline : 080-41241458

E-mail: [info@kylaserworks.com](mailto:info@kylaserworks.com)

Website: [www.kylaserworks.com](http://www.kylaserworks.com)

Innovation with Perfection